

SPECTROLINE®

NDT

uVision™ Series

UV-A/White Light LED NDT Inspection Lamp
Part No. UV-365HCR



RoHS
Compliant



TESTED
TO COMPLY WITH



ASTM E3022-18
Standard



6/22 AM18013ML-5
PRINTED IN U.S.A

Find Quality Products Online at:

www.GlobalTestSupply.com

sales@GlobalTestSupply.com

WARNING

**UV emitted from this product. Avoid eye and skin exposure to unshielded products.
FOR PROFESSIONAL EXAMINATION USE ONLY**

IMPORTANT SAFETY INSTRUCTIONS (Read all instructions)

- Do not operate the uVision™ Series UV-A/White Light LED NDT Inspection Lamp (UV-365HCR) with a damaged cord or if the lamp has been physically damaged.
- Do not look directly into the light. **ALWAYS** wear the UV-absorbing protective glasses provided when operating the lamp. Use in low-light conditions to achieve the best inspection results. The darker the room, the greater the fluorescent contrast.
- The uVision™ is not approved for use in hazardous atmospheres. Do not attempt to use it in areas requiring explosion-proof lighting.
- Never use this equipment in any manner not specified in these instructions because your protection may be impaired.
- **NEVER** aim the lamp in the direction of another human being. **It is meant for professional fluorescent inspections ONLY!**
- **DO NOT** attempt to modify the lens assembly or light output. Doing so may alter the performance and intensity of the uVision™.

OPERATION

- The uVision™ series UV-A inspection lamps are equipped with a heavy-duty power cord.
- The lamp is shipped with the correct cord installed for the country of destination.
- Connect the plug to a power source that complies with the electrical requirements specified on the label.
- The lamp has a three-position rocker power switch (II – UV; O – off; I – white light) on the handle.
- **WARNING:** Be sure to use genuine uVision™ replacement parts. Using another manufacturer's replacement parts could affect product performance and will void the warranty.
- The UV-365HCR White Light Intensity Adjustment Controls are located on the back plate of the lamp. Select the preferred white light intensity setting. The Power Indicator is also located on the back plate of the lamp.



CHANGING THE LAMP POWER SUPPLY

The appropriate cord for the country of destination will be installed on the lamp when it is ordered. The power cord is integrated into the lower portion of the lamp handle, forming a cord/handle assembly. A set of detailed instructions for changing the lamp cord come with the replacement parts. Contact Customer Service for more details.

DISASSEMBLING THE FILTER PROTECTOR FOR MAINTENANCE

The outer rubber cover/filter holder may be removed periodically to clean the Borofloat® glass filter. To disassemble the Borofloat® Filter Protector (FP-600), first remove the front rubber cover/filter holder. Peel the rubber cover/filter holder toward the front portion of the lamp.



The Borofloat® glass filter will remain inside the protector. To remove the Borofloat® glass filter, peel around the edge of the rubber cover/filter holder and push the glass filter out. To replace or reinsert the Borofloat® glass filter into the rubber cover/filter holder, slide the Borofloat® glass filter into the channel of the rubber cover/filter holder. Manipulate the rubber cover around the filter. Ensure the glass filter is evenly seated.

REPLACING THE UV LENSES

The UV-A lenses (UL-110) covering the three UV-A LEDs must be replaced over time. They will solarize (become cloudy and yellow) from repeated use. A set of detailed instructions come with the replacement UV-A lenses (UL-110). See Replacement Parts section and contact Customer Service for more details.

ENVIRONMENTAL SPECIFICATIONS

- The uVision™ series lamps are designed to be safe under the following conditions:
- For Indoor/Outdoor Use (dustproof and protected against jets of water);
 - Temperature 41°F to 122°F (5°C to 50°C);
 - Mains supply voltage fluctuations not to exceed ±10% of the nominal voltage;

LIMITED WARRANTY

The warranty policy for the uVision™ lamp is provided on the Certificate of Limited Warranty enclosed separately with each unit. **NOTE:** For assistance of any kind, please contact the Customer Service Department at Spectro-UV. Provide the model, the serial number of the unit, and the date of purchase. The unit's serialization information is located (1) on the packaging the unit is shipped in, (2) engraved on the unit's handle, and (3) labeled on the reverse side of the unit's back plate.



BATTERY LED INDICATOR STATUS
Orange = Power on, battery good
Blink Orange and Red = Low Battery; time left approx. 10 – 15 mins
Red = Dead Battery, Approx. 5 minutes or less remaining
Shut Down

MEASURING LAMP INTENSITY

To ensure that your uVision™ series lamp is operating at the required UV intensity, it should be checked periodically. Spectro-UV offers a variety of sensors and meters. The AccuPRO™ XP-2000 combines the functionality of a UV and visible light radiometer/photometer, and is specially designed to measure UV irradiance with wavelengths of 320–400nm (with peak at 365nm) and visible light from 460–675nm (with peak at 555nm). Other suitable meters include the AccuMAX™ XRP-3000 radiometer/photometer kit, using dual-wavelength UV-A and VIS sensor detectors to accurately measure the irradiance of a light source. The AccuMAX™ XR-1000 digital readout unit with the XS-365 UV sensor or the DM-365XA digital readout unit can also be used for UV-A measurement. For more information about these units, please contact the Customer Service Department at Spectro-UV. Call toll-free 1-866-230-7305.

KEY FEATURES

- 50 Foot (15 Meter) Retractable Power Cord Reel
- Nominal steady state intensity of 6,000 µW/cm² at 15 inches (38cm).
- Large 6.4-inch diameter coverage area at 15 inches (38cm) with a minimum UV-A intensity of 1,200 µW/cm² (ASTM E3022-15).
- Less than 1.0 foot-candle (11 lux) emission.
- Long-lasting UV-A lenses.
- Cool running, fanless design.
- Lightweight and rugged construction.
- White Light, LED Inspection Light.
- IP65 Rated: The uVision™ Series lamps are protected from total dust ingress and from low pressure jets of water (from all directions). For more details, consult EN 60529 (British BS EN 60529:1992, European IEC 60509:1989).
- Certificate of Conformance (ASTM E3022-15) included.

TECHNICAL SPECIFICATIONS

uVision™ Series

UV-365HCR	UV-A (365nm) and white light
Height	7.5 inches
Length	4.25 inches
Width	3.75 inches
Weight	15.45 lb. (including Reel and Power Supply)
Light Source	3 UV-A LEDs, 1 white light LED

ELECTRICAL SPECIFICATIONS

Input: 100-240V AC, 0.9, 50-60 Hz
Output: 15V DC, 2.4A



POWER CORD SPECIFICATIONS

LAMP PART NUMBER	POWER REQUIREMENTS*
UV-365HCR	120V/50–60Hz
UV-365HCR/F	230V/50Hz
UV-365HCR/FA	240V/50Hz
UV-365HCR/FB	230V/50Hz
UV-365HCR/FBR	220-240V/50-60Hz

UV-365HCR EXPLODED VIEW AND REPLACEMENT PARTS

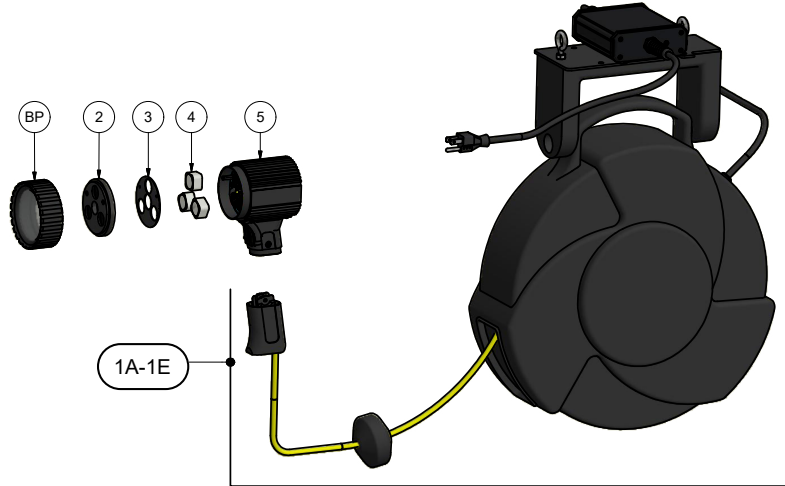

Replacement Parts

ITEM	QTY	PART NO.	DESCRIPTION
1A	1	130405	POWER SUPPLY, REEL, 50FT, UVISION, 120V, US
1B	1	130406	POWER SUPPLY, REEL, 50FT, UVISION, 230V, EU
1C	1	130407	POWER SUPPLY, REEL, 50FT, UVISION, 240V, AU
1D	1	130408	POWER SUPPLY, REEL, 50FT, UVISION, 230V, UK
1E	1	130504	POWER SUPPLY, REEL, 50FT, UVISION, 220-240V, BR
BP	1	FP-600	BOROFLOAT® FILTER PROTECTOR ASSEMBLY
2	1	128196	FRONT COVER PLATE / UV-A FILTER ASSEMBLY
3	1	128385	FRONT COVER GASKET
4	3	UL-110	UV LED LENS, WITH ADHESIVE
5	1	130336	LAMP HOUSING ASSEMBLY

Accessories

QTY	PART NO.	DESCRIPTION
1	UVS-30	UV-ABSORBING SPECTACLES

CORD REEL INSTRUCTIONS

INSTALLATION

Lamp-Ballasted Models (Ceiling Mount)

- Select a location within proximity to an electrical outlet.
- Suspend the lamp assembly from a suitable ceiling mount. Connect a chain to the ceiling mount. Next, fasten the chain to the eyebolts located on the topside of the unit. Make certain the unit is balanced.

OPERATION

- Connect the primary cord to a power outlet that complies with the electrical requirements listed on the lamp.
- Pull the cord out to the desired length and stop. If the cord does not hold, continue to pull the cord slowly, stopping every 4 inches (10 cm). This will engage the lock. To retract, pull the cord out 2 to 4 inches (5 to 10 cm) and guide the cord slowly back into the reel.
- Do not pull hard on the cord when it is fully extended to 50 feet (15.2 m). This will cause retracting spring to malfunction.
- Do not allow the cord to fly unrestricted back into the reel.

MAINTENANCE

- Remove dirt and grime as soon as it accumulates on the reel case. Wipe clean with a dampened cloth. Do not use solvents such as gasoline, turpentine, etc., to clean the unit.
- Keep the cord clean to ensure the smoothest automatic retraction. Pull the cord to its full length and allow it to retract through a clean, dampened cloth. Pull out the full length again and allow it to retract through a clean, dry cloth sprinkled with talcum powder.

GENERAL SAFETY INFORMATION

- This unit should be used indoors. Do not use near potentially dangerous locations such as flammable or explosive atmospheres or near water.
- Use only 3-wire extension cords that have 3-prong grounding plugs and 3-pole receptacles that accept the unit's plug.
- Disconnect the unit from the power supply before servicing or inspecting it for any reason.

WORK AREA SAFETY

Keep work area clean, dry, free of clutter, and well lit. Cluttered, wet, or dark work areas can result in injury. Using the tool in confined work areas may put you dangerously close to other cutting tools and rotating parts. Be aware of all power lines, electrical circuits, water pipes, and other mechanical hazards in your work area. Some of these hazards may be below the work surface hidden from your view and may cause personal harm or property damage if unintentionally contacted.

ELECTRICAL GROUNDING

This reel must be grounded to protect the operator from electrical shock. The plug MUST be plugged into a matching receptacle that is properly installed and grounded in accordance with ALL local codes and ordinances. DO NOT MODIFY THE PLUG PROVIDED. If it will not fit the receptacle, have the proper receptacle installed by a qualified electrician. CHECK with a qualified electrician or service person if you do not completely understand the grounding instructions, or if you are not sure the tool is properly grounded.

UV-365HCR Setup

