



User Manual
English
Version 2.0

Leica
Geosystems

Automatic level

Congratulations on your purchase of a NA2/NAK2 automatic level.



This manual contains important safety directions as well as instructions for setting up the product and operating it. Refer to "Safety Directions" for further information. Read carefully through the User Manual before setting up the product.

Product identification

The model and the serial number of your product are indicated on the housing.
Enter the model and serial number in your manual and always refer to this information when you need to contact your agency or Leica Geosystems authorized service workshop.

Type: _____ Serial no.: _____

Symbols

The symbols used in this manual have the following meanings:



DANGER:

Indicates an imminently hazardous situation which, if not avoided, will result in death or serious injury.



WARNING:

Indicates a potentially hazardous situation or an unintended use which, if not avoided, could result in death or serious injury.



CAUTION:

Indicates a potentially hazardous situation or an unintended use which, if not avoided, may result in minor or moderate injury and/or appreciable material, financial and environmental damage.



Important paragraphs which must be adhered to in practice as they enable the product to be used in a technically correct and efficient manner.

View of chapters

Introduction 7

Measurement preparation 10

Measuring 14

Checking and adjusting 20

Care and Storage 22

Safety Directions 25

Accessories 32

Technical Data 34

Index 35

Contents

Introduction	7	Checking and adjusting of the line-of-sight	21
Special features	7	Care and Storage	22
Important parts	8	Transport	22
Technical terms and abbreviations	9	In the field	22
Measurement preparation	10	Inside vehicle	23
Case contents	10	Shipping	23
Setting up the tripod	11	Storage	23
Levelling up	12	Cleaning	24
Focusing telescope	13	Safety Directions	25
Centring	13	Intended use of instrument	25
Measuring	14	Permitted uses	25
Height reading	14	Adverse uses	25
Distance measuring	15	Limits of use	26
Angle measuring	15	Responsibilities	27
Line levelling	16	Hazards of use	28
Area levelling	17	Accessories	32
Levelling total station measuring	18	Technical Data	34
Levelled stakeout	18	Index	35
Precise levelling	19		
Checking and adjusting	20		
Tripod	20		
Circular level	20		

Introduction

The NA2/NAK2 universal automatic level meets all precision, convenience and reliability requirements. Its innovative technology will make daily surveying jobs easier.

The instrument is ideally suited for all levelling applications and at all orders of accuracy.

The instantaneous check facility with the push-button control promotes confidence.

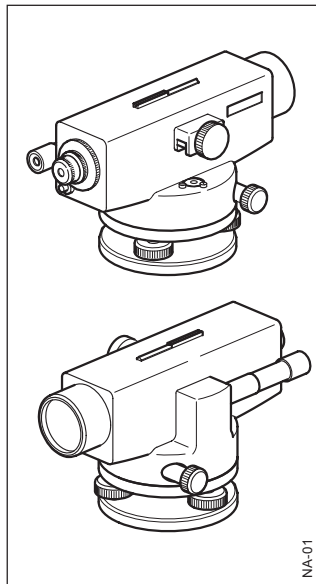

Special features

- Easy operation, quick to learn!
- Robust and reliable.
- High setting accuracy.
- Endless drive.
- Telescope with excellently-corrected optics for bright, high-contrast images.
- Enables angle measurements with internal glass circle (NAK2 model).
- Optional parallel-plate micrometer for precise fine levelling.

NA2/NAK2-2.0.0en

7

Introduction

Important parts

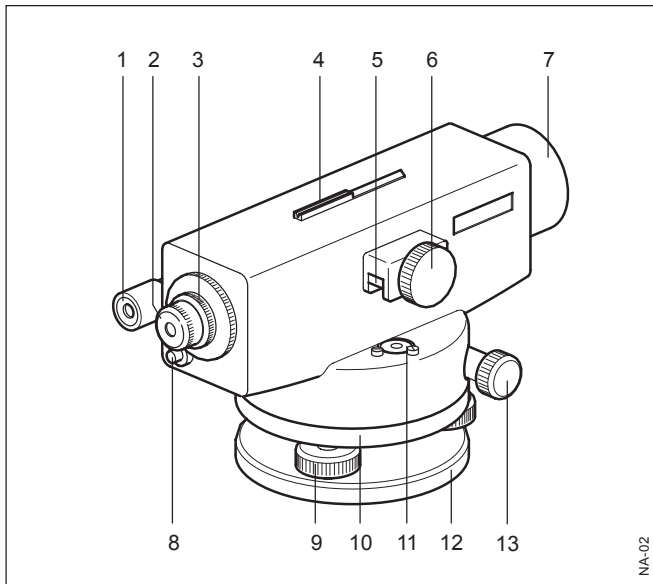

- 1 Eyepiece of scale microscope (NAK2 only)
- 2 Telescope eyepiece
- 3 Bayonet ring, locks eyepiece in place
- 4 Open sight
- 5 Prism for viewing circular level
- 6 Rapid/fine focussing knob
- 7 Objective housing
- 8 Push-button for compensator control
- 9 Footscrew
- 10 Milled rim, for Hz-circle setting (NAK2 only)
- 11 Circular level
- 12 Base plate
- 13 Endless horizontal drive (both sides)

NA2/NAK2-2.0.0en

Technical terms and abbreviations

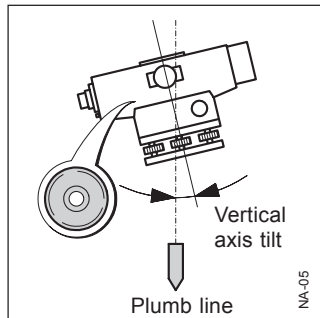

Plumb line

By centring the circular level the instrument is almost level. A small instrument tilt remains (the vertical axis tilt).

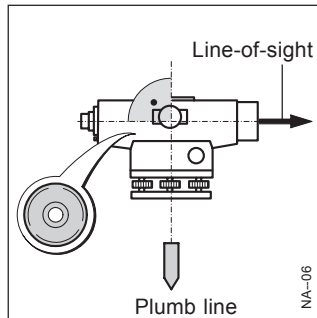

Compensator

The compensator in the instrument is responsible for compensating the vertical axis tilt enabling an exactly horizontal aiming. The push button gives the pendulum a slight tap to check the functioning of the compensator.

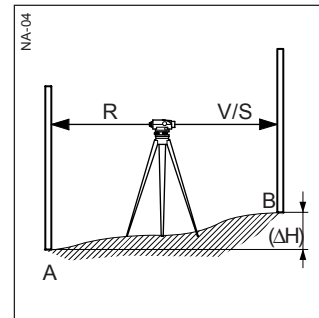

Backsight/Foresight/ Intermediate sight

For determining the height difference (ΔH) between the ground points A and B the back sight (R) is measured first followed by the forward sight (V). Additional points relating to A are measured as intermediate sight (S).

Measurement preparation

Case contents

Remove NA2/NAK2 level from the case and check that all components are present.

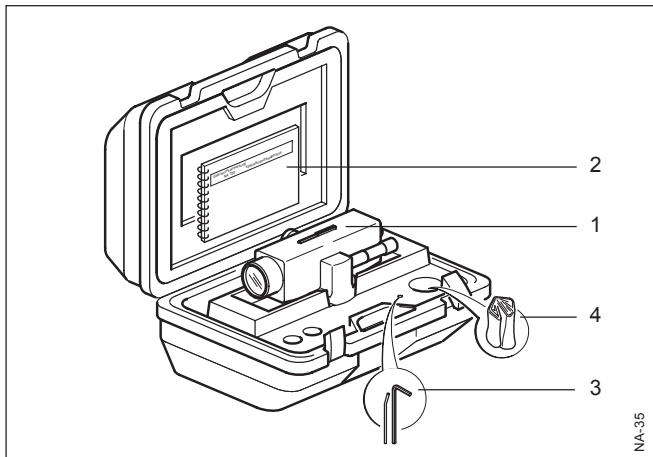

- 1 Level
- 2 User Manual
- 3 Allen key/Adjusting pins
- 4 Protective cover & sun shade

NA2/NAK2-2.0.0en

Setting up the tripod

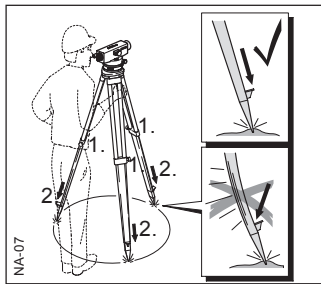

1. Loosen screws of tripod legs, pull out to required length and tighten screws.

2. In order to guarantee a firm foothold sufficiently press the tripod legs into the ground.

When pressing the legs into the ground note that the force must be applied along the legs.

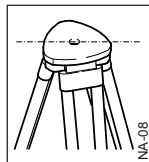

When setting up the tripod pay attention to a horizontal position of the tripod plate.

Large inclinations of the tripod must be corrected with the footscrews of the tribrach.

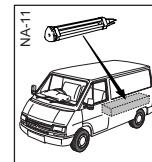
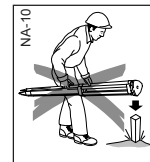
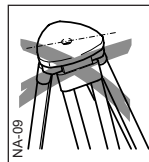

Careful handling of tripod

- Check all screws and bolts for correct fit.
- During transport always use the cover supplied.

Scratches and other damages can result in poor fit and measuring inaccuracies.

- Use the tripod only for surveying jobs.

Levelling up



1. Place level onto tripod head. Tighten central fixing screw of tripod.
2. Turn footscrews of tribrach into centre position.
3. Centre circular level by turning the foot screws.

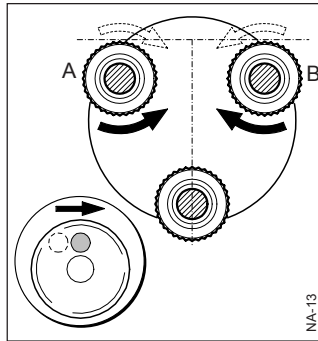

Centring the circular level

1. Turn foot screws A and B simultaneously in opposite directions until bubble is in the centre (on the imaginary "T").

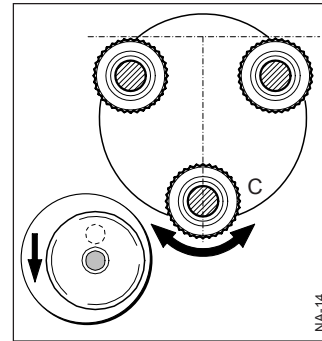

2. Turn foot screw C until bubble is centred.

Focusing telescope

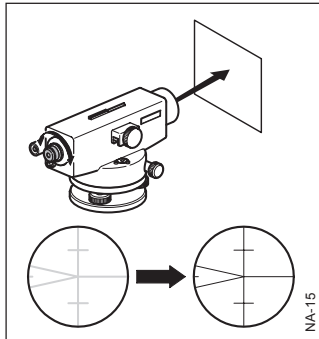

1. Aim telescope against a bright background (e.g. white paper).
2. Turn eyepiece until reticle is sharp-focused and black. Now the eyepiece is adjusted to your eye.

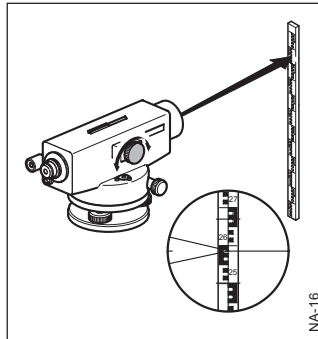

3. Aim telescope on staff using the coarse aiming device.
4. Turn focusing knob until image of staff is sharply focused. If the eye is moved up and down behind the eyepiece the image of the staff and the reticle should not move relative to each other.

Centring

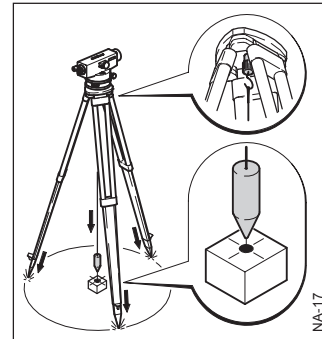



For centring over a ground point:

1. Attach plumb bob.
2. Loosen central fixing screw slightly and shift instrument parallel on tripod until the plummet is exactly over the point.
3. Tighten central fixing screw.

Measuring

 Before starting field work or after longer periods of storage/transport of your equipment check the field adjustment parameters specified in this User Manual.

 Reduce possible vibrations by holding the tripod legs.

 If the optical parts of your instrument are dirty or fogged, your measurements can be affected. Keep clean all optical parts of your instrument and follow the cleaning instructions specified in the User Manual.

 Before starting work, let the instrument adjust to the ambient temperature (approximately 2 minutes per °C of temperature difference).

Height reading

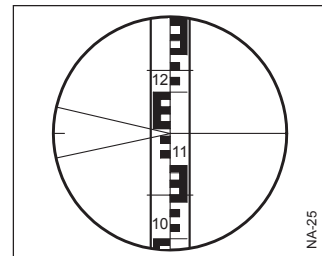
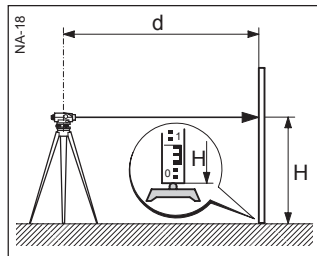

1. Setup instrument, level and sharp-focus the reticule.
2. Setup level staff vertically (refer also to Instruction Manual of staff).
3. Roughly aim on staff using the coarse aiming device.
4. Sharp-focus using the focusing knob.
5. Fine-aim on staff using the endless drives.
6. Check if circular level is centred (view level prism).
7. Press the button to verify that the compensator is functioning.
8. Read off height H at the horizontal reticule hair.
Example above: $H=1.143$

Distance measuring

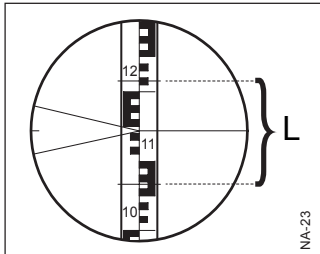

Carry out steps 1 to 8 according to height reading.

Reading:

Upper distance line: 1.216 m
Lower distance line: 1.068 m

Difference L: 0.148 m
Distance d: 14.8 m

Result:
Distance $d = 100 \times L$

NA2/NAK2-2.0.0en

Angle measuring

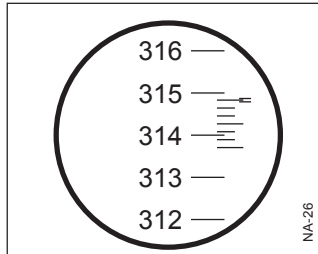

Circle reading 314°42'

The NAK2 is equipped with a horizontal circle. The graduation is 1° or 1 gon.

To measure an angle bring the vertical hair of the reticule to the centre of the staff.

By turning the milled ring, the circle can be set to "0" or any desired reading.



Circle reading 392.66°

The circle is viewed through the scale microscope and sharply focussed by turning the microscope eyepiece.

The Hz-angle is read from the graduation line which protrudes into the scale. Each scale line represents 10'. The minutes are read from the top scale line to the circle graduation line.

Line levelling

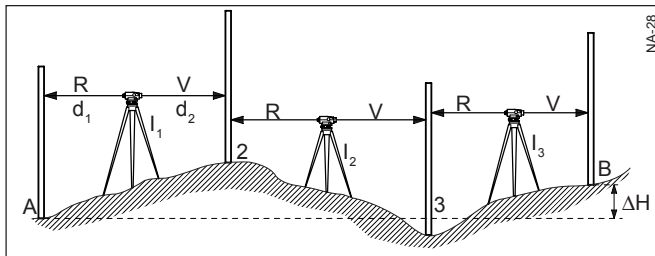

Project:

Height difference (ΔH) between point A and B.



Select instrument station and staff location by pacing off such that approx. the same target distances result ($d_1 \approx d_2$; approx. 40 to 50m).

Procedure:

1. Setup instrument at I_1 .

2. Setup level staff vertically at point A.
3. Aim at staff and read off and take down height (backsight R).
4. Setup level at the changepoint 2, aim at staff and read off and take down height (foresight V).
5. Setup level at I_2 , aim at staff at the changepoint 2 and read backsight and take down.

6. Carry out a foresight at changepoint 3.
7. Continue in the same way until height at point B is measured.

Result:
 $\Delta H = \text{sum backsight} - \text{sum foresight}$

Example of the booking:

Point No.	Back-sight R	Fore-sight V	Height
A	+2.502		650.100
2	+0.911	-1.803	
3	+3.103	-1.930	
B		-0.981	651.902
Sum	+6.516	-4.714	$\Delta H = +1.802$

Area levelling

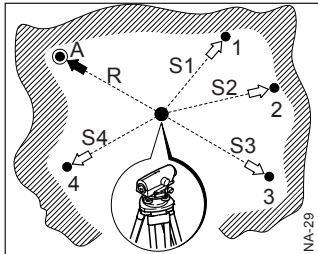

Project:

Height difference of several reference points.



The required accuracy is usually not very high with such measurements. Nevertheless, from time to time read the staff on a stable intermediate point (reading must remain the same).

Procedure:

1. Set up instrument centrally between the desired points. The instrument telescope may not be below the highest measured intermediate point.
2. Set up staff vertically at reference point A.
3. Aim at staff and read and take down height (=backsight to known point).
4. Set up staff vertically at point 1.
5. Aim at staff and read and take down height (=measuring intermediate point, intermediate sight)
6. Repeat steps 4 and 5 for additional intermediate points.

7. The height of individual points are:

$$\text{Height} = \text{Height of station point} + \text{backsight (A)} - \text{intermediate sight}$$

Example of booking:

Point No.		Intern. sight	Height
A	592.00		
R1	+2.20		
⊗	594.20		
S1		-1.80	592.40
S2		-1.90	592.30
S3		-2.50	591.70
S4		-2.30	591.90

⊗ = Instrument horizon

Levelling total station measuring

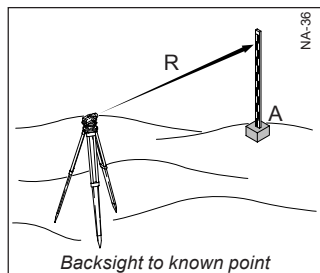

Wanted:

Position of several ground points.



The levelling total station measuring is normally carried out during area levelling.

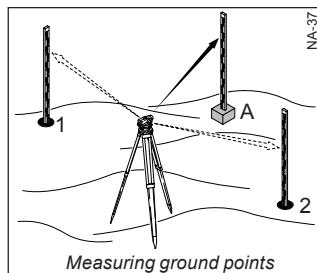

Procedure:

1. Sequence of measurements is the same as with area levelling. However, beside the height read also the staff section L (see chapter "Distance measuring") and the Hz-angle.
2. Transfer measured value into the map - points are determined by position and height.

Levelled stakeout

The stakeout is the counterpart to the levelling total station measuring - map points are set out in the field.

Procedure:

1. Set up instrument at a known point, centre and level up.
2. Focus instrument and aim on known orientation point.
3. Orient horizontal circle (Hz-direction).
4. Move staff to stakeout point on the basis of known values (distance and Hz-angle, height) and stakeout point

Precise levelling

Project:

Height difference of very high accuracy.

 Use the GPM3 parallel plate micrometer and invar levelling staffs.

 In sloping terrain, the lower part of the staff should not be used, as refraction close to the ground can cause errors.

 In sunny weather an umbrella should be used to shelter the instrument to ensure that the level is protected from the glare of the sun.

Procedure:

1. Sequence of measurements is the same as with line levelling. However, the best observing length is approx. 25m.
2. When reading the staff, turn the micrometer knob until a graduation line is centred between the wedge-shaped hairs of the reticle.
3. Centimetres are read from the staff and millimetres from the micrometer scale.
4. Leica invar staffs have two sets of graduations. These are read alternatively between foresight and backsight. This provides two independent results and serves as a check.

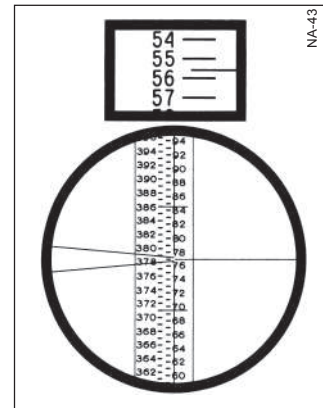

Example above:

Staff reading = 77 cm
GPM3 reading = 0.556 cm
Height = 77.556 cm

Checking and adjusting

Tripod

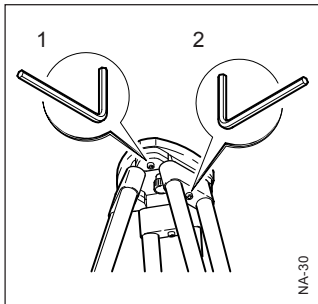

Connection of individual elements must always be tight.
1. Tighten the Allen screws (2) moderately (if available).
2. Tighten the articulated joints on the tripod head (1) just enough to keep the tripod legs open when you lift it off the ground.

Circular level

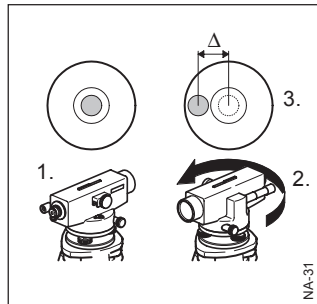

1. Level up instrument.
2. Turn instrument by 180°.
3. If bubble of level is outside the circle then it should be adjusted (see point 4).

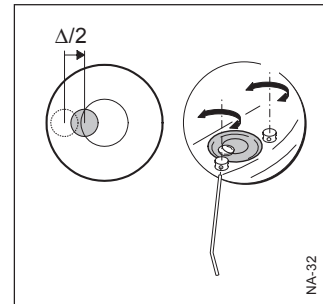

4. Correct the half error using an adjusting pin and repeat steps 2 and 3 until the bubble of level is in the centre in any telescope direction.

Checking and adjusting of the line-of-sight

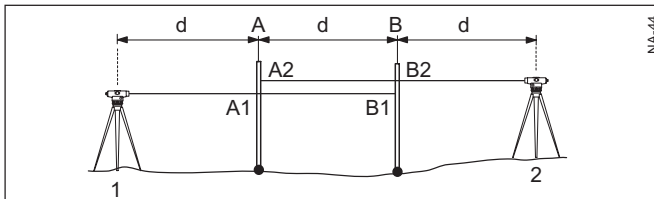

NA-44

Checking (see figure):

1. Choose a flat terrain between 45 and 60 m long and divide into three equal sections d .
2. Set up a staff at points A & B.
3. Set up the level at point 1, centre the bubble and press the compensator button.
4. Readings A1 and B1 are taken to the staffs.
5. Set up the level at point 2.
6. Readings A2 and B2 are taken to the staffs.
7. Find nominal reading A2; Reading $A1 - B1 + B2$

8. Compare the nominal/actual-reading for A2.

Parallel plate micrometer

When using the parallel plate micrometer to perform precise levelling, follow the same check procedure using invar staffs and micrometer reading. When adjusting, the micrometer is set to the correct value and the adjusting screw is turned until the horizontal hair is on the staff graduation.

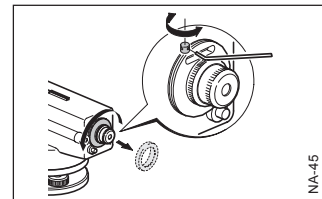

NA-45

When the difference nominal/actual- reading is more than 2 mm the line of sight must be adjusted.

1. Screw off the protective cover.
2. Turn the adjusting screw until the horizontal hair gives the nominal reading A2 on staff A. The last turn of the adjusting screw should be clockwise.
3. Screw on the protective cover.
4. Repeat the checking procedure.

Care and Storage

Transport

 When transporting or shipping the equipment always use the original Leica Geosystems packaging (transport case and shipping cardboard).

 After a longer period of storage or transport of your product always check the field adjustment parameters indicated in this manual before using the product.

In the field

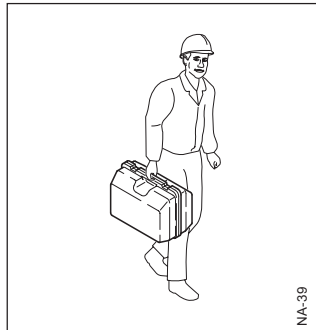

When transporting the equipment **in the field**, always make sure that you

- either carry the product in its original transport container,

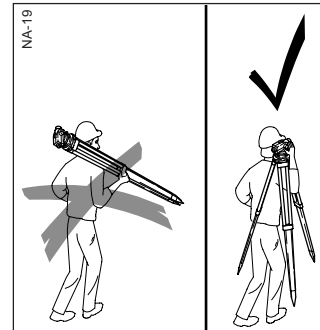

- carry the tripod with its legs splayed across your shoulder, keeping the attached product upright.

Inside vehicle

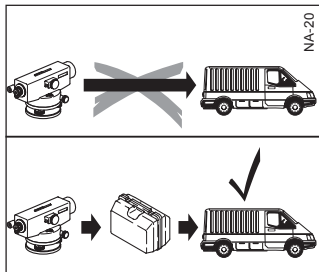

Never carry the product loose in a road vehicle, as it can be affected by shock and vibration. Always carry the product in its transport container and secure it.

Shipping

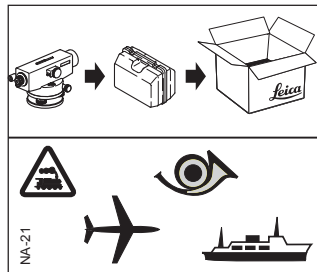

When transporting the product by rail, air or sea, always use the complete original Leica Geosystems packaging, transport container and cardboard box, or its equivalent, to protect against shock and vibration.

Storage

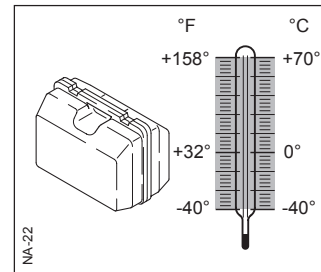

Respect the temperature limits when storing the equipment, particularly in summer if the equipment is inside a vehicle. Refer to "Technical Data" for information about temperature limits.

If the equipment is to be stored for a long time, remove the alkaline batteries from the GEB63 battery box in order to avoid the danger of leakage.

Storage, continued

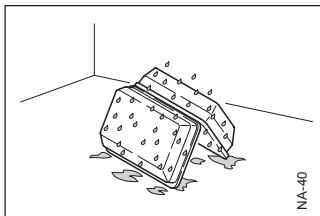

 **If the instrument becomes wet, leave it unpacked.** Wipe down, clean, and dry the instrument (at not more than 40 °C/ 104°F), transport case, foam inserts, and accessories. Pack up the equipment only when it is completely dry.

When using the instrument in the field always close the transport case.

Cleaning

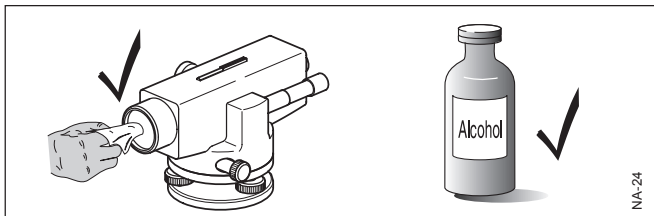

 **Objective, eyepiece:**

- Blow dust off lenses and prisms
- Never touch the glass with your fingers
- Use only a clean, soft, lint-free cloth for cleaning. If necessary, moisten the cloth with water or pure alcohol.

Do not use other liquids; these may attack the polymer components.

Safety Directions

The following directions should enable the person responsible for the product, and the person who actually uses the equipment, to anticipate and avoid operational hazards.

The person responsible for the product directions and adhere to them.

Intended use of instrument

Permitted uses

The level is intended to the following applications:

- Line and area levellings
- Height readings
- Precision levelling with attachable parallel-plate micrometer
- Optical distance measuring with stadia readings
- Angle measurements and staking out with horizontal circle (only NAK2 model)

Adverse uses

- Use of the product without instruction
- Use outside of the intended limits
- Disabling safety systems
- Removal of hazard notices
- Opening the product using tools, for example screwdriver, unless this is specifically permitted for certain functions.
- Modification or conversion of the product
- Use after misappropriation
- Use of products with obviously recognizable damages or defects

Adverse uses, contd.

- Use with accessories from other manufacturers without the prior explicit approval of Leica Geosystems
- Aiming directly into the sun
- Inadequate safeguards at the surveying site, for example when measuring on roads



WARNING:

Adverse use can lead to injury, malfunction and damage. It is the task of the person responsible for the equipment to inform the user about hazards and how to counteract them. The product is not to be operated until the user has been instructed on how to work with it.

Limits of use

Environment:

Suitable for use in an atmosphere appropriate for permanent human habitation: not suitable for use in aggressive or explosive environments. Use in rain is permissible for limited periods (splash-water proof).



DANGER:

Local safety authorities and safety experts must be contacted before working in hazardous explosive areas, or in close proximity to electrical installations or similar situations by the person in charge of the product.

Responsibilities

Manufacturer of the product:
Leica Geosystems AG, CH-9435 Heerbrugg, hereinafter referred to as Leica Geosystems, is responsible for supplying the product, including the user manual and original accessories, in a completely safe condition.

Manufacturers of non Leica Geosystems accessories:
The manufacturers of non Leica Geosystems accessories for the product are responsible for developing, implementing and communicating safety concepts for their products, and are also responsible for the effectiveness of those safety concepts in combination with the Leica Geosystems product.

Person in charge of the product:
The person in charge of the product has the following duties:

- To understand the safety instructions on the product and the instructions in the user manual.
- To be familiar with local regulations relating to safety and accident prevention.
- To inform Leica Geosystems immediately if the product and the application becomes unsafe.



WARNING:

The person responsible for the product must ensure that it is used in accordance with the instructions. This person is also accountable for the training and the deployment of personnel who use the product and for the safety of the equipment in use.

Hazards of use



WARNING:

The absence of instruction, or the inadequate imparting of instruction, can lead to incorrect or adverse use, and can give rise to accidents with far-reaching human, material, financial and environmental consequences.

Precautions:

All users must follow the safety directions given by the manufacturer and the directions of the person responsible for the product.



CAUTION:

Watch out for erroneous measurement results if the product has been dropped or has been misused, modified, stored for long periods or transported.

Precautions:

Periodically carry out test measurements and perform the field adjustments indicated in the user manual, particularly after the product has been subjected to abnormal use and before and after important measurements.



DANGER:

Because of the risk of electrocution, it is very dangerous to use poles and extensions in the vicinity of electrical installations such as power cables or electrical railways.

Precautions:

Keep at a safe distance from electrical installations. If it is essential to work in this environment, first contact the safety authorities responsible for the electrical installations and follow their instructions.



Hazards of use, continued



WARNING:

By surveying during a thunderstorm you are at risk from lightning.

Precautions:

Do not carry out field surveys during thunderstorms.



CAUTION:

Be careful when pointing the product towards the sun, because the telescope functions as a magnifying glass and can injure your eyes and/or cause damage inside the product.

Precautions:

Do not point the product directly at the sun.



WARNING:

Inadequate securing of the surveying site can lead to dangerous situations, for example in traffic, on building sites, and at industrial installations.

Precautions:

Always ensure that the survey site is adequately secured. Adhere to the regulations governing safety and accident prevention and road traffic.

Hazards of use, continued



CAUTION:

If the accessories used with the product are not properly secured and the product is subjected to mechanical shock, for example blows or falling, the product may be damaged or people may sustain injury.

Precautions:

When setting-up the product, make sure that the accessories, for example tripod, staff, staff brace are correctly adapted, fitted, secured, and locked in position.

Avoid subjecting the product to mechanical stress.

Never position the product on the tripod baseplate without securely tightening the central fixing screw. If the screw is loosened always remove the product immediately from the tripod.



CAUTION:

When using a vertical staff supported by one brace there is always the danger of falling, for example by wind gusts and therefore danger of damage to equipment and danger of personal injuries.

Precautions:

Never leave a vertical staff supported by a brace unsupervised (person at the staff).

Hazards of use, continued



WARNING:

If the product is improperly disposed of, the following can happen:

- If polymer parts are burnt, poisonous gas are produced which may impair health.
- If batteries are damaged or are heated strongly, they can explode and cause poisoning, burning, corrosion or environmental contamination.
- By disposing of the product irresponsibly you may enable unauthorized persons to use it in contravention of the regulations, exposing themselves and third parties to the risk of severe injury and rendering the environment liable to contamination.

Precautions:

Dispose of the product appropriately in accordance with the regulations in force in your country.

Always prevent access to the product by unauthorized personnel.

Accessories

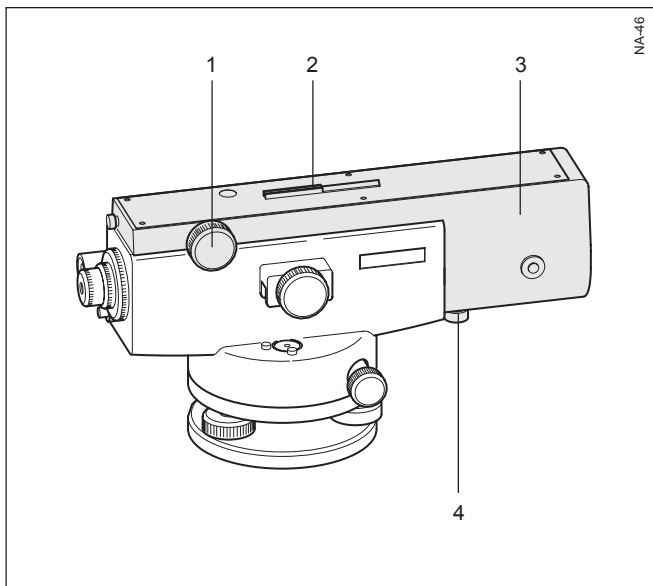

GPM3 Parallel-Plate Micrometer (Art. No. 356 121)

- 1 Micrometer knob
- 2 Open sight
- 3 Housing of parallel plate
- 4 Knob for locking GPM3 in position

For precise levelling the GPM3 is fitted onto the NA2 telescope objective and locked in position with the knob (4).

By turning the micrometer knob the parallel-sided glass plate is tilted, thereby causing the line of sight to be raised or lowered. The range of displacement is 10mm. On the scale, seen in the GPM3's eyepiece, the amount of displacement is read directly to 0.1mm and estimated to 0.01mm.

Accessories, continued

GOA2 Autocollimation eyepiece

(Art. No. 199899)
Release the bayonet ring to replace eyepieces. With the autocollimation eyepiece the NA2 can be used for alignment purposes in the laboratory and industry.

GFZ3 Diagonal eyepiece

(Art. No. 734514)
The diagonal eyepiece can be fitted for observing from any side when working in confined spaces.

FOK73 Eyepiece 40x

(Art. No. 346475)
For precise levelling with the parallel plate micrometer, the FOK73 eyepiece giving 40x magnification may be preferred.

GVO10 Auxiliary lens

(Art. No. 335958)
When short focussing distances are required, the auxiliary lens can be fitted to the objective. Measuring range is 1.8 to 0.9m.

GEB60 Eyepiece lamp with cable

(Art. No. 394785)
With the eyepiece lamp the NA2 can be used as a collimator for horizontal sighting.

GEB62 Plug-in lamp with cable

(Art. No. 394787)
This plug-in lamp can be used with the GOA2 autocollimation eyepiece.

GEB63 Battery box

(Art. No. 394792)
Power supply for autocollimation eyepiece and eyepiece lamp.

Technical Data

Accuracy:

- Standard deviation for 1km double levelling, depending on staffs and procedure up to 0.7 mm
- With GPM3 parallel-plate micrometer (optional) 0.3 mm

Telescope:

- Vertical image
- Magnification, standard eyepiece 32 x
FOK 73 eyepiece 40 x
- Clear objective diameter 45 mm
- Field of view at 100 m 2.2 m
- Shortest target distance from instrument axis 1.6 m

Distance measurement:

- Multiplication factor 100
- Additive constant 0

Compensator:

- Working range $\pm 30'$
- Setting accuracy (stand. dev.) 0.3"

Circular level:

- Sensitivity 8' / 2 mm

Glass circle of NAK2:

- Graduation 360° or 400 gon
- Graduation diameter 70 mm
- Graduation interval 1° or 1 gon
- Optical scale interval 10' or 10°
- Reading by estimation to 1' or 1°

Temperature range:

- Storage -40°C to 70°C
(-40°F to 158°F)
- Operating -20°C to 50°C
(-4°F to 122°F)

GPM3 parallel-plate micrometer: (optional accessory)

- Range 10 mm
- Interval 0.1 mm
- Estimation 0.01 mm

NA2/NAK2-2.0.0en

Index

A	Accident prevention	29	F	Focusing	13, 33
	Angle measuring	15			
	Area levelling	17			
B	Booking	16, 17	H	Height difference	9, 16, 17
	Bubble	12, 20		Horizontal circle	15
				Hz-angle	18
				Hz-circle	15
C	Central fixing screw	12	L	Line levelling	16
	Centring	13		Line-of-sight	21
	Circular level	12, 14, 20			
	Cleaning	24	O	Optical sight	13
	Compensator	9			
D	Distance line	15	P	Packaging	23
				Plumb bob	13
E	Electrical installations	28		Plummet	13
	Environment	26		Precise levelling	19, 32
	Eyepiece	13, 33			

Index, continued

R	Rearrangement point	16	V	Vibrations	14
	Reticule	13, 14			
S	Safe distance	28	W	Wet instrument	24
	Sharp-focus	14			
	Shipping	22, 23			
	Stakeout	18			
	Storage	22, 24			
	Storing	23			
T	Target distances	16			
	Total station measuring	18			
	Transport	22			
	Transport case	22, 24			
	Tripod	20			

Leica Geosystems AG, Heerbrugg, Switzerland, has been certified as being equipped with a quality system which meets the International Standards of Quality Management and Quality Systems (ISO standard 9001) and Environmental Management Systems (ISO standard 14001).



***Total Quality Management-
Our commitment to total customer
satisfaction.***

*Ask your local Leica Geosystems
agent for more information about
our TQM program.*